

FLINT

Femtosecond Yb Oscillators

FEATURES

- < 40 fs pulse duration
- Up to 260 nJ pulse energy
- Up to 20 W output power
- 76 MHz repetition rate
- No amplified spontaneous emission
- Industrial-grade design
- Optional automated second harmonic generator
- Optional CEP stabilization
- Optional repetition rate locking to an external source



FLINT-FL2

FLINT oscillators are based on an Yb crystal pumped by a high-brightness laser diodes. Generation of femtosecond pulses is provided by Kerr lens mode-locking. Once started, mode-locking remains stable over a long period and is immune

to minor mechanical impact. Oscillator cavity length can be adjusted using an optional piezo actuator. FLINT oscillators can also be equipped with carrier-envelope phase (CEP) stabilization and repetition rate locking to an external source.

SPECIFICATIONS

Model	FL1-02	FL1-08	FL1-SP	FL2-12	FL2-20	FL2-SP
Maximum output power	2 W	8 W	2 W ¹⁾	12 W	20 W	2 W ¹⁾
Pulse duration ²⁾	< 100 fs	< 120 fs	30 ... 50 fs ¹⁾	< 120 fs	< 170 fs	30 ... 50 fs ¹⁾
Maximum pulse energy ³⁾	26 nJ	105 nJ	26 nJ ¹⁾	157 nJ	260 nJ	26 nJ ¹⁾
Repetition rate	≈ 76 MHz ⁴⁾		≈ 76 MHz ⁵⁾	≈ 76 MHz		≈ 76 MHz ⁵⁾
Center wavelength	1035 ⁶⁾ ± 10 nm	1030 ± 3 nm	1040 ± 10 nm	1029 ± 3 nm	1026 ± 2 nm	1040 ± 10 nm
Pulse-to-pulse energy stability ⁷⁾	RMS deviation ⁸⁾ < 0.5% over 24 h					
Polarization	Linear, horizontal					
Beam quality	TEM ₀₀ ; M ² < 1.2					
Beam pointing stability	< 10 μrad/°C					
Internal 2H generator	n/a		Optional; conversion efficiency > 30%			
Internal attenuator	n/a		Yes			

PHYSICAL DIMENSIONS

Laser head (L × W × H)	430 × 195 × 114 mm	542 × 322 × 146 mm
Power supply and chiller rack (L × W × H)	642 × 553 × 540 mm	642 × 553 × 673 mm
Chiller	Different options available. Contact sales@lightcon.com	

ENVIRONMENTAL & UTILITY REQUIREMENTS

Operating temperature	15–30 °C (air conditioning recommended)		
Relative humidity	< 80% (non-condensing)		
Electrical requirements	110 V AC, 50–60 Hz, 2 A or 220 V AC, 50–60 Hz, 1 A		
Rated power	200 W		
Power consumption	100 W	150 W	
Power consumption (chiller)	200 W	800 W	200 W

¹⁾ Maximum output power and pulse energy depends on the chosen pulse duration, e.g., < 50 fs – 2 W, 26 nJ, < 40 fs – 1 W, 13 nJ.

²⁾ Assuming Gaussian pulse shape.

³⁾ Depends on repetition rate. Approximate values are given for 76 MHz repetition rate.

⁴⁾ Other repetition rates are available in the range from 60 to 100 MHz.

⁵⁾ Other repetition rates are available in the range from 70 to 80 MHz.

⁶⁾ Choice of a particular central wavelength with ±1 nm tolerance is available upon request.

⁷⁾ With enabled power-lock, under stable environment.

⁸⁾ Normalized to average pulse energy, NRMSD.

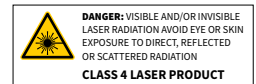

CEP STABILIZATION

FLINT oscillators can be equipped with feedback electronics for carrier-envelope phase (CEP) stabilization of the output pulses. The carrier-envelope offset (CEO) of the oscillator is actively locked to 1/4th of the repetition rate with a <100 mrad standard deviation.

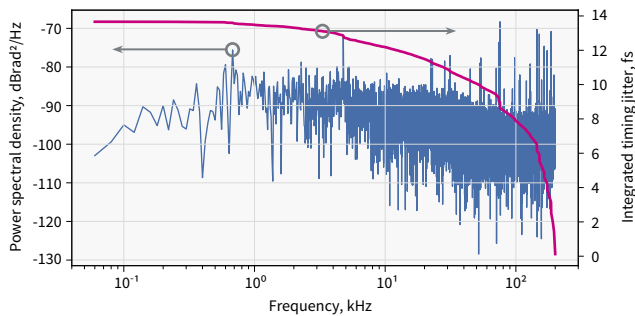

Phase noise data of CEP locked FLINT oscillator

REPETITION RATE LOCKING

FLINT oscillators are customizable for repetition rate locking applications. Coupled with the necessary feedback electronics, the repetition rate can be synchronized to an external RF source using the two piezo stages installed inside the cavity.

The repetition rate locking system can assure an integrated timing jitter of less than 200 fs for RF reference frequencies larger than 500 MHz. Continuous phase shifting is available on request.

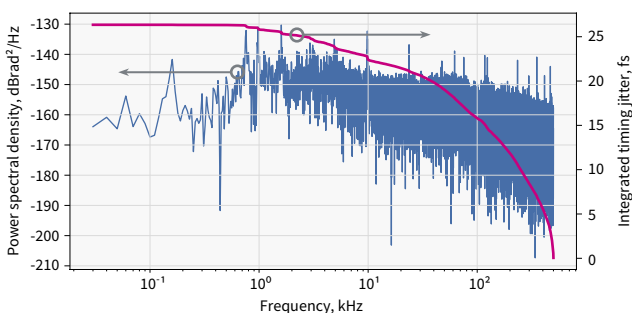

Phase noise data of FLINT oscillator locked to a 2.8 GHz RF source

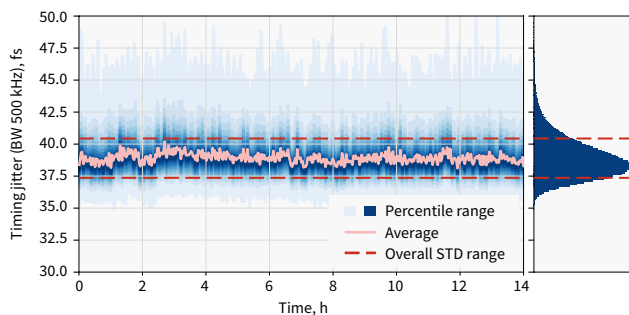

Timing jitter stability over 14 h; FLINT oscillator locked to a 2.8 GHz RF source

PERFORMANCE

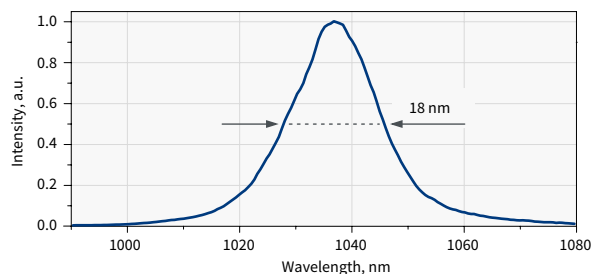

Typical FLINT optical spectrum

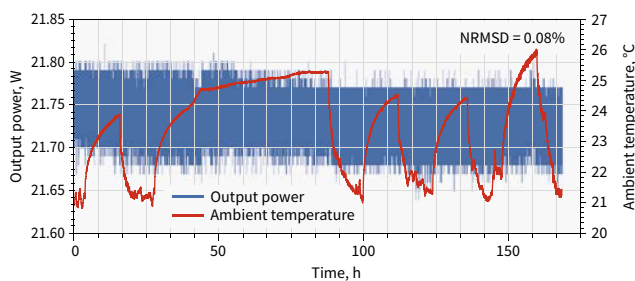

FLINT-FL2-20 (20 W) output power stability under harsh environmental conditions

DRAWINGS

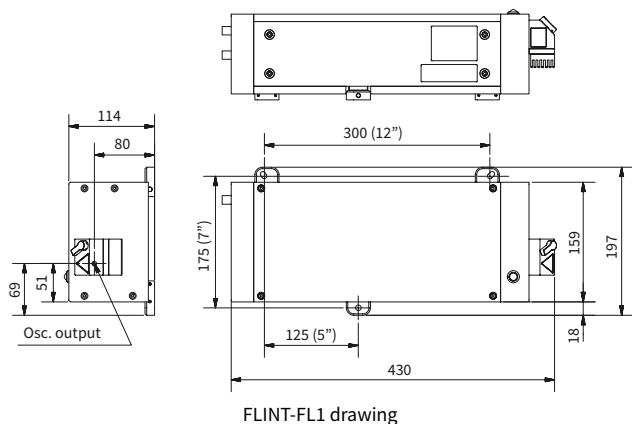

FLINT-FL1 drawing

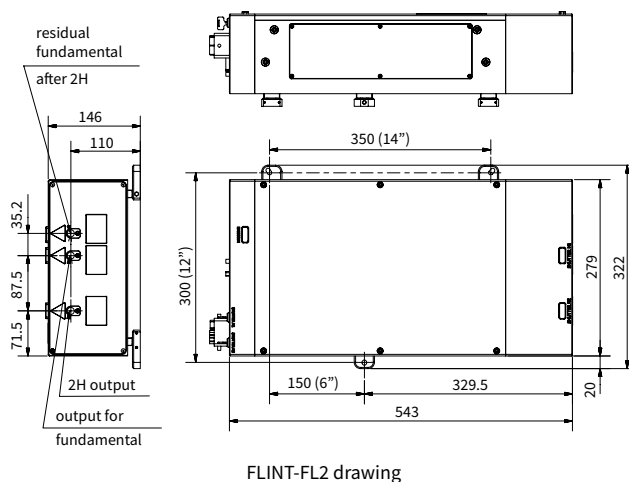

FLINT-FL2 drawing