

AXIALSCAN-30 DIGITAL II HP



3-AXIS DEFLECTION UNITS

FOR CHALLENGING INDUSTRIAL APPLICATIONS



- For large areas with small spot sizes and 3D applications
- For laser power up to 4 kW
- Control via SL2-100 protocol 20 bit or XY2-100 protocol 16 bit
- Digitally controlled high-speed Z axis
- Optimized long-term drift for highly challenging process quality

LARGE PROCESSING FIELDS WITH THE SMALLEST SPOT SIZES

YOUR BENEFITS

The AXIALSCAN-30 Digital II HP deflection units with the LT-II-20 digital linear translator module offer not only the smallest spot diameters with large processing areas, but also flexibility, high deflection speed, long-term stability and exceptionally low drift values at 20 bit position resolution. Thanks to optimized lenses for CO₂ wavelength and 1,060 nm – 1,070 nm, they can handle laser power up to 4 kW. Heat development is greatly reduced thanks to the PWM output stages used.

INTERFACES

Deflection units are compatible with both XY2-100 (16 bit) and SL2-100 (20 bit). The units are controlled digitally using a control card, such as SP-ICE-3 or SP-ICE-1 PCIe PRO.

TYPICAL APPLICATIONS

Material processing, such as cutting, perforating, welding, drilling, bleaching, processing of moving parts, 3D applications, additive manufacturing.

DEFLECTION MIRRORS AND LENSES

Lenses, protective glass and deflection mirrors are available for all standard laser sources.

INNOVATION AND QUALITY

Innovation and maintaining high product quality standards are our priorities at RAYLASE. All our products are developed, built and tested in our own laboratories and production facilities. Through our worldwide support network we can offer best maintenance and rapid service for our customers.

AXIALSCAN-30 DIGITAL II HP

GENERAL SPECIFICATIONS

Power supply	Voltage	30 V or 48 V	Ambient temperature	+15°C to +35°C
	Current	3A, RMS, max. 10 A	Humidity	≤ 80 % non-condensing
	Ripple/Noise	Max. 200 mVpp, @ 20 MHz bandwidth	Total weight	approx. 14.5 kg
Interface signals	Digital	XY2-100-Enhanced protocol SL2-100-protocol	Max. input aperture	20 mm
			Tracking error (ms) LT-II-20	1.5 ms

TYPE DEPENDING SPECIFICATIONS - DEFLECTION UNIT

Deflection unit	SUPERSCAN IV-30 QU	SUPERSCAN IV-30 SC	SUPERSCAN V-30 SC
Mechanical data:			
Input aperture (mm)	30	30	coming soon
Beam displacement (mm)	35.38	35.98	
Weight (kg)	approx. 5,5	approx. 5,5	
Galvo-Scanner specific data:			
Typical deflection (rad)	± 0.393	± 0.393	
Repeatability RMS (µrad)	< 2.0	< 2.0	
Max. Gaindrift (ppm/K) ¹	15	15	
Max. Offsetdrift (µrad/K) ¹	10	10	
Long-term drift 8 h without water temperature control (µrad) ¹	< 60	< 60	
Long-term drift 8 h with water temperature control (µrad) ^{1, 2}	< 40	< 40	
Dynamic data:			
Positioning speed (rad/s) ³	30.0 @ 30 V 50.0 @ 48 V	40.0 @ 30 V 65.0 @ 48 V	
Tracking error (ms)	0.5	0.32	
Step response time at 1% of full scale (ms) ⁴	1.2	0.8	

¹ Angles optical. Drift per axis, after 30 min warm-up, at constant ambient temperature and process stress.

² After 30 min warm-up, under varying process stress with water temperature control not less than 2 l/min and 22°C.

³ See "Calculation speed in field". ⁴ Setting to 1/5,000 of full scale.

Calculation speed in field

1 rad/s @ ± 0.393 rad deflection (45°) ≈ 0.12 m/s for 100 mm working field size

Example: AXIALSCAN-30 Digital II HP with SUPERSCAN IV-30-SC, Working field size 400 mm x 400 mm (≈ field factor = 4), Positioning speed 65 rad/s:

=> 65 x 0.12 m/s x 4 = 31.2 m/s. Note: Lower speeds may be produced by the linear translator module, depending on which control card is used, the laser job, field size and optical configuration.

TYPE DEPENDENT SPECIFICATIONS - TUNING

Tuning	Description
Vector-Tuning	Optimized tuning for a wide application spectrum and main focused on the processing speed; other tunings on request

Deflection mirrors and protective glass:

Protective glass and scan mirrors are available for all standard laser types, wavelengths, power densities, focal lengths and processing areas.

Custom solutions can also be provided. For more information about possible combinations, simply contact the RAYLASE Support Team

at +49 8153 88 98-0 or support@raylase.de.

Options:

The SUPERSCAN IV and SUPERSCAN V deflection units provide two types of water-connections for the electronic components and galvanometer scanners: straight (W) connectors and 90° (W2) connectors along with air-cooling (A) of the deflection mirrors. This ensures constant working conditions and excellent long-term stability, thus guaranteeing reliable operation even in high power laser applications.

The SUPERSCAN IV and SUPERSCAN V deflection units can also be operated without temperature control by cooling water. In consequence the drift values may increase.

WATER TEMPERATURE CONTROL

Specifications	
Water ¹	Clean tap water with additives
Temperature	22°C – 28°C
Max. water pressure	< 3 bar

¹ **Caution:** When using cooling water including deionised water, suitable additives must be used to prevent the growth of algae and protect the aluminium parts against corrosion.

Additive recommendations (Please consult your additive supplier for dosage information):

Standard industrial applications: Products of company NALCO, e.g. CCL105

Food & beverage, packaging applications: Polypropylene glycol of company Dow Chemical, e.g. DOWCAL N

Flow rate ²	Pressure drop ²
2 l/min	0.8 bar
4 l/min	1.6 bar
6 l/min	2.4 bar

² Flow rate and pressure drop valid for serial water flow from deflection unit to LT-II-20.

CONFIGURATION EXAMPLES: CO₂ (λ = 10,600 NM) AXIALSCAN-30 CHP 200 WITH LINEAR TRANSLATOR MODULE LT-II-20 [CHP] ZS-[W20/W220]-VC-SX/S2

Field size (mm x mm)	200 x 200	300 x 300	400 x 400	500 x 500	600 x 600
Distance D (mm) ¹	127	103	90	83	78
Working distance (mm) ²	198	321	445	569	693
Spot diameter 1/e ² (μm) ³	195	287	379	471	563
Free focus range (mm)	10	57	142	276	476

CONFIGURATION EXAMPLES: CO₂ (λ = 10,600 NM) AXIALSCAN-30 CHP 600 WITH LINEAR TRANSLATOR MODULE LT-II-20 [CHP] ZS-[W60/W260]-VC-SX/S2

Field size (mm x mm)	600 x 600	700 x 700	800 x 800	1,000 x 1,000	1,200 x 1,200
Distance D (mm) ¹	180	168	160	148	140
Working distance (mm) ²	693	816	940	1,188	1,435
Spot diameter 1/e ² (μm) ³	553	643	734	915	1,096
Free focus range (mm)	13	46	90	213	390

CONFIGURATION EXAMPLES: YAG (λ = 1,064 NM) AXIALSCAN-30 YHP 300 WITH LINEAR TRANSLATOR MODULE LT-II-20 [YHP] QU-[W30/W230]-VC-SX/S2

Field size (mm x mm)	300 x 300	500 x 500	800 x 800	1,000 x 1,000	1,200 x 1,200
Distance D (mm) ¹	146	117	100	95	91
Working distance (mm) ²	321	569	940	1,188	1,435
Spot diameter 1/e ² (μm) ³	31	50	78	98	117
Free focus range (mm)	16	125	516	1,015	1,839

¹ Front end of the linear translator up to the interior of the housing plate; length may vary depending on laser divergence and lens tolerances.

² From the bottom edge of deflection unit or the output plate to the processing field. ³ Input beam quality: M² = 1.0

LENSE SPECIFICATIONS

Laser	Nd:YAG	CO ₂
Wavelength (nm)	1,064	10,600
Max. laser power, cw (W)	4,000 ¹	2,500 ²

¹ QU-Mirrors

² SC-Mirrors

AXIALSCAN-30 DIGITAL II HP



3-AXIS DEFLECTION UNITS

FOR CHALLENGING INDUSTRIAL APPLICATIONS

AXIALSCAN-30 Digital II HP (SS-IV-30 + LT-II-20 [CHP200] und [YHP300])

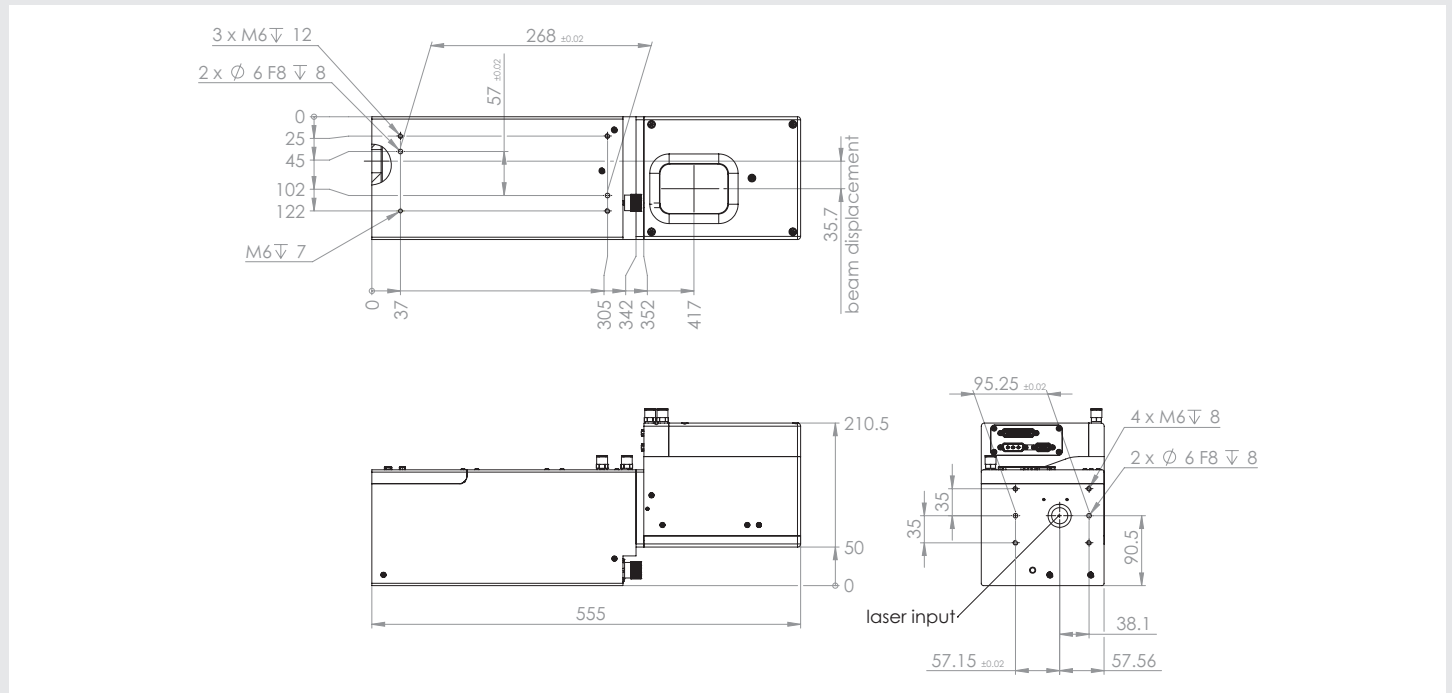

AXIALSCAN-30 DIGITAL II HP (SS-IV-30 + LT-II-20 [CHP600])

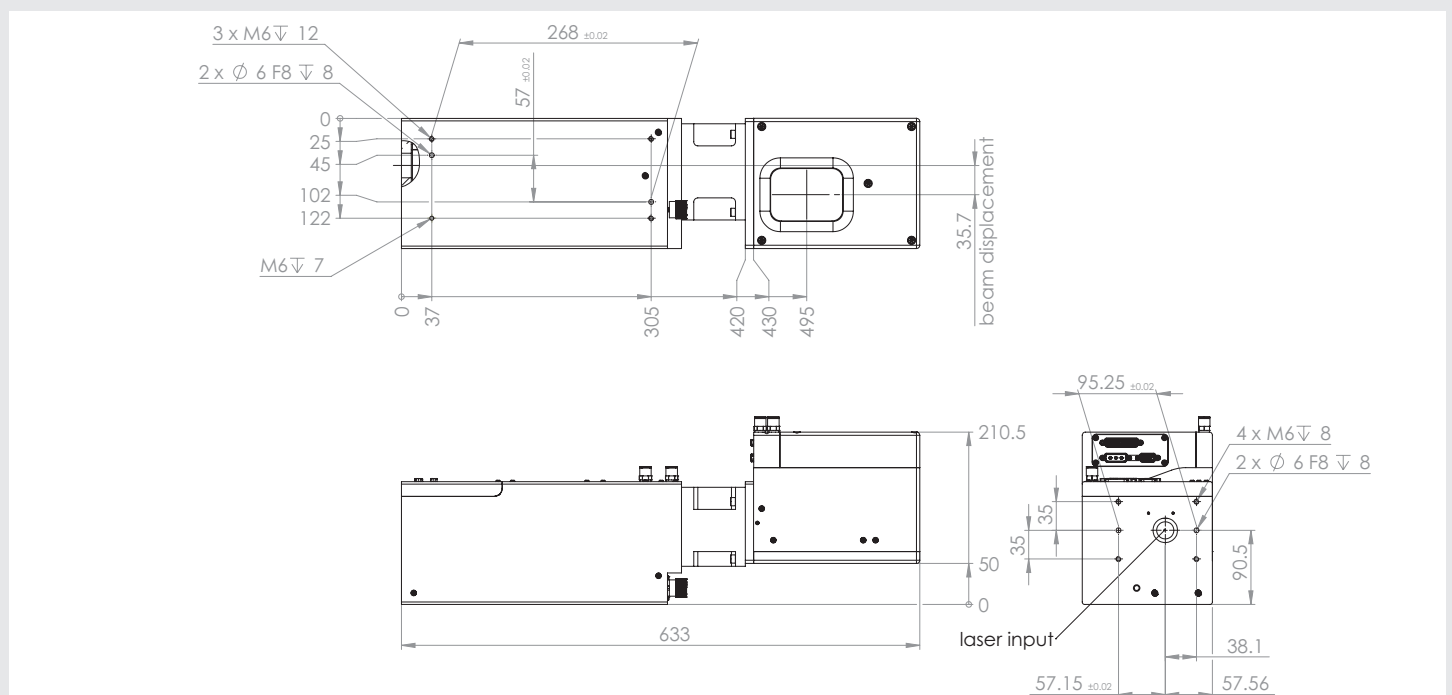

All trademarks are registered trademarks of their owner.

Headquarters:
RAYLASE GmbH
 Wessling, Germany
 ☎ +49 8153 88 98-0
 ✉ info@raylase.de

Subsidiary China:
RAYLASE Laser Technology (Shenzhen) Co.
 Shenzhen, China
 ☎ +86 755 28 24-8533
 ✉ info@raylase.cn

Subsidiary USA:
RAYLASE Laser Technology Inc.
 Newburyport, MA, USA
 ☎ +1 978 255-1672
 ✉ info@raylase.com

